



Vehicle History Report

VEHICLE DETAILS

Chassis number ¹: Z34-300323

Manufacture date: 2011-02

Make: NISSAN

Model: FAIRLADY Z

Body: CBA-Z34

Grade: VERSION ST

Engine: VQ37VHR

Drive: 2WD

Transmission: AT

Title information ²:  **Registered** 

Accident / Repair:  **No problem** 

Odometer rollback:  **No problem** 

Manufacturer recall:  **No problem** 

Safety grade ³:  **No data** 

Contamination risk:  **No problem** 

This CAR VX Vehicle History Report is based only on Information supplied to CAR VX, LTD and available as of 2026-01-08 21:45:42. Other information about this vehicle, including problems, may not have been reported to CAR VX, LTD . Use this report as one important tool, along with a vehicle inspection and test drive, to make a better decision about your next used car.

ACCIDENT / REPAIR HISTORY

Problem type	Reported	Date reported	Data source	Details	Airbag
Collision	Not reported				
Malfunction	Not reported				
Theft	Not reported				
Fire damage	Not reported				
Water damage	Not reported				
Hail damage	Not reported				

ODOMETER READINGS HISTORY

Date reported	Data source	Odometer reading (Km)
2022-02-18	MLIT	83800
2024-02-05	MLIT	97900
2025-12-16	USS Yokohama	111073

USE HISTORY

Use in the contaminated regions ⁴	Radioactive contamination test fail ⁵	Commercial use
Not reported	Not reported	Not reported

DETAILED HISTORY

Event date	Location	Odometer reading (Km)	Data source	Details
2011-02			NISSAN	Manufactured
2011-02			MLIT	First registration
2011-02-22	Kumagaya		MLIT	Last registration
2022-02-18		83800	MLIT	Inspection
2024-02-05	Kumagaya	97900	MLIT	Inspection

MANUFACTURER RECALL HISTORY

Date reported	Data source	Affected part	Details
---------------	-------------	---------------	---------

 Not reported

VEHICLE ASSESSMENT ⁶

Overall Collision Safety Ratings

Driver's seat			Front passenger's seat		
Points	Evaluation	Goal average	Points	Evaluation	Goal average
0		0%	0		0%

* In order to accurately differentiate between the evaluations of different vehicles, a standard is set based on current technology. Up to 6 points out of 12 is given level 1 and the rest of the range is divided up into equal parts, which are respectively assigned to level 2 (more than 6 points but 7.5 or less), level 3 (more than 7.5 points but 9 or less), level 4 (more than 9 points but 10.5 or less) or level 5 (more than 10.5 points).

Braking performance tests ⁷

Dry road



Wet road



VEHICLE SPECIFICATION

1st gear ratio	4.923	2nd gear ratio	3.193
3rd gear ratio	2.042	4th gear ratio	1.411
5th gear ratio	1.000	6th gear ratio	0.862 7 SPEED0.771
Additional notes		Airbag position, capacity	-
Body rear overhang	765	Body type	COUPE

Chassis number embossing position	COWL TOP PANEL RIGHT SIDE	Classification code	0012
Cylinders	V6 LENGTHWAY	Displacement	3690
Electric engine type	-	Electric engine maximum output	-
Electric engine maximum torque	-	Electric engine power	-
Engine maximum power	247/7000(NET)	Engine maximum torque	365/5200(NET)
Engine model	VQ37VHR	Frame type	SOLID STRUCTURE
Front shaft weight	840	Front shock absorber type	
Front stabilizer type	TORSION BAR TYPE	Front tires size	245/40R19 94W 275/35R19 96W
Front tread	1540	Fuel consumption	9.4
Fuel tank equipment	72	Grade	VERSION ST
Height	1315	Length	4250
Main brakes type	HYDRAULIC TYPE DISK HYDRAULIC TYPE DISK	Make	NISSAN
Maximum speed	180	Minimum ground clearance	125
Minimum turning radius	5.2	Model	FAIRLADY Z
Model code	CBA-Z34	Mufflers number	
Rear shaft weight	690	Rear shock absorber type	
Rear stabilizer type	TORSION BAR TYPE	Rear tires size	245/40R19 94W 275/35R19 96W
Rear tread	1565	Reverse ratio	3.972
Riding capacity	2	Side brakes type	
Specification code	16216	Stopping distance	45(100)
Transmission type	AT	Weight	1530
Wheel alignment	2WD	Wheelbase	2550
Width	1845		

AUCTION DATA

Date: 2025-12-16, Auction: USS Yokohama, Lot #: 30245

Date:	2025-12-16	Lot #:	30245
Auction name:	USS Yokohama	Region:	Kanagawa
Make:	NISSAN	Model:	FAIRLADY Z
Reg. year:	2011	Mileage (km):	111073
Displacement (cc):	3700	Transmission:	FA
Color:	BLACK	Model code:	Z34
Result:	available	Auction grade:	4
Problem type:	No problem	Problem scale:	None
Contaminated:	No	Airbag:	OK

PHOTOS AND AUCTION SHEETS

国産プライムコーナー

30245	車種 (国産用には記入)	排気量	型式	4
		3700	CBA-Z34	
	初年度登録年月 H23/2月	車名 フェアレディZ	グレード バージョンST	2WD

車検 R 8年 2月 21日	シフト	FAT	特注品
走行 111,073 km	冷房	AAC	SR (有) PS (有) PV (有)
外色 元色 色番	カラー名	セールスポイント ☆オークション初出品 ☆ユーザー買取車 ☆ワンオーナー ☆バックモニター ☆ハーフレザーシート	カワ TV ナビ エアD
クロ →	G41		
燃料 ガソリン	内装色	有	
輸入区分	ハンドル	月 日	

リサイクル 販売金 9,650円	乗車定員 2人	登録地 熊谷 331 す 234
○注意事項 (納車・不具合説明および状態等)		車台 No. Z34-300323
☆保証書・取説後送		シリアル No.

○検査員報告

ダッシュ板ワレ、ベタつき
シートヒビ、ハゲ
ハンドルスレ

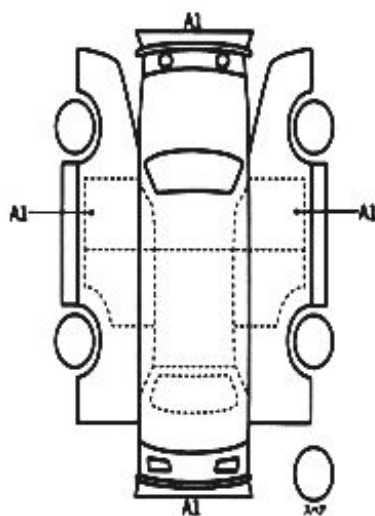

[荷台内寸]約	x	x	(BOX)	(cm)	
長さ	425 cm	幅	184 cm	高さ	131 cm

¹ Chassis number – a unique identification number of the vehicle in Japan (same as VIN in the USA or Europe)

² Title information:

Registered – qualified for driving in Japan

Deregistered Temporarily – not qualified for driving in Japan, usually a temporary title during the ownership change

Deregistered Completely – not qualified for driving in Japan, the vehicle is determined to be scrapped

Deregistered to Export – not qualified for driving in Japan, the vehicle is determined to be exported

³ Determining the overall collision safety performance evaluation – For the driver's seat, the results of the full-wrap frontal collision test, offset frontal collision test, and side collision test are added together and evaluated to 6 different levels. For the Frontal passenger's seat, the results of the full-wrap frontal collision test and the side collision test (results for the driver's or the front passenger's seat are used) are added together and evaluated to 6 different levels.

Regular vehicle inspection – All vehicles in Japan must undergo regular vehicle inspections (shaken). New cars need to be tested after three years, and then vehicles must be tested every two years thereafter. A vehicle inspection (shaken) is compulsory for all vehicles with an engine size over 250cc. It ensures that all vehicles on the road are properly maintained and safe to drive. The test also checks that vehicles have not been illegally modified; if they are found to have been modified, they are not allowed on the road.

⁴ Use in the contaminated regions – The Fukushima Daiichi nuclear disaster was a catastrophic failure at the Fukushima I Nuclear Power Plant on 11 March 2011, resulting in a meltdown of three of the plant's six nuclear reactors. As a result, some areas in the following prefectures were contaminated: Fukushima, Miyagi, Ibaraki, Tochigi.

⁵ Radioactive contamination test – radioactive contamination inspection that was started in July 2011 as a preventive measure for exporting contaminated vehicles from Japan. The inspection is being conducted since in all sea ports of Japan under the supervision of The Japan Harbor Transportation Association (JHTA).

MLIT – Ministry of Land, Infrastructure, Transport and Tourism.

⁶ Japan New Car Assessment Program – the Ministry of Land, Infrastructure, Transport and Tourism (MLIT) and the National Agency for Automotive Safety & Victims' Aid (NASVA) have taken measures for safety, one of which is to assess commercially available vehicles through a variety of safety performance tests and release the resulting information compiled into the "New Car Assessment Program". The objective of Japan New Car Assessment Program is to increase the use of safe automobiles by providing an environment in which users can easily select such vehicles. This also promotes the development of safer vehicles by automobile manufacturers. Neck injury protection for rear-end collision performance test, rear seat passenger's protection for frontal collision performance test, rear passenger's seat belt usability evaluation test and seat belt reminder for passengers evaluation test are started in FY2009.

⁷ Braking Performance Tests – Braking performance is determined by the shortness of the distance in which a vehicle can stop and the stability of the vehicle at the time of braking. This test is performed under wet and dry road conditions for a vehicle which has both a driver and a front passenger. The distance it takes for the vehicle to stop and the stability of the vehicle at the time of braking is evaluated for when the vehicle is stopped abruptly while traveling at a speed of 100km/h. The stopping distance and vehicle speed have been measured by using GPS since FY2009.

CAR VX, LTD DEPENDS ON ITS SOURCES FOR THE ACCURACY AND RELIABILITY OF ITS INFORMATION. THEREFORE, NO RESPONSIBILITY IS ASSUMED BY CAR VX, LTD OR ITS AGENTS FOR ERRORS OR OMISSIONS IN THIS REPORT. CAR VX, LTD FURTHER EXPRESSLY DISCLAIMS ALL WARRANTIES, EXPRESSED OR IMPLIED, INCLUDING ANY IMPLIED WARRANTIES OF MERCHANTABILITY OR FITNESS FOR A PARTICULAR PURPOSE.

© 2014-2026 Car VX Limited. All rights reserved.